

**RADIUS**  
SYSTEMS



# Electrofusion Fittings

for water, wastewater, gas, power  
& renewable energy applications

APRIL 2026

Innovators in pipeline technologies

# ELECTROFUSION FITTINGS

## Technologically advanced joining solutions

Specifically designed for ease of assembly and to provide optimum efficiency during the welding process, our range of universal black electrofusion fittings offers specifiers and installers a high performance jointing solution for their whole polyethylene (PE) pipeline system.

Our extensive industry knowledge in the design and manufacture of electrofusion fittings means that we are continually developing

smarter solutions that offer maximum joint integrity, are easy to install and are robust in operation. Our strength in innovation is also delivering for our customers, as we bring to market technologically advanced fittings that provide installation time savings and efficiencies, with a service life of over 100 years when installed correctly.

Our fittings are manufactured in our ISO 9001, ISO 14001 and ISO 45001 accredited facilities. They are extensively tested in our dedicated laboratories, providing the assurance of a high performance fitting solution for your PE pipeline network.



### Features and Benefits

- Manufactured from high strength polyethylene (PE100)
- Exposed wire technology for maximum heat transfer during the fusion process
- Patented Easigrip® technology for large diameter fittings for ease of handling during installation
- 80V couplers significantly save on installation time due to shorter fuse times
- Simultaneous socket fusion for all fittings
- A range of lightweight profiled fittings for ease of use
- A range of universal fittings
- Barcode technology - for automatic temperature compensating fusion times and fitting traceability
- Manual fusion times on the body of the fitting
- Corrosion resistant
- End-load bearing jointing system
- Manufactured with insertion stops to ensure the pipe is fully engaged



### Approvals

Our electrofusion fittings are approved to the most stringent national, international or in-house specifications and some of our fittings have been developed for specific markets or to meet particular customer requirements.

#### Gas

- BS EN 1555-3 - KM 596928
- GIS/PL2-4 - KM 538462
- DVGW GW 335-B2
- MPA Darmstadt - K 1598/12.2014
- IIP Certification of Conformity to EN 1555-3

#### Water and wastewater

- BS EN 12201-3 - KM 597648
- WRAS approved materials
- DVGW GW 335-B2
- MPA Darmstadt - K 1597/12.2014
- IIP Certification of Conformity to EN 12201-3

*For individual fitting approval(s), please contact Radius Systems.*

## Electrofusion fittings maximum operating pressure (MOP)

Our electrofusion fittings are tested for use with PE80 and PE100 pipes in a wide range of SDRs, with MOP in accordance with national and international specifications:

- UK gas specification - GIS/PL2-4 up to 5.5 bar or 7 bar
- European gas specification - BS EN 1555-3 up to 10 bar
- European water specification - BS EN 12201-3 up to 16 bar

Due to our extensive offering, some fittings within our range may have a lower maximum operating pressure than quoted above. For the most up to date information relating to the fitting, please refer to the fitting's packaging label or contact Radius Systems for more information.

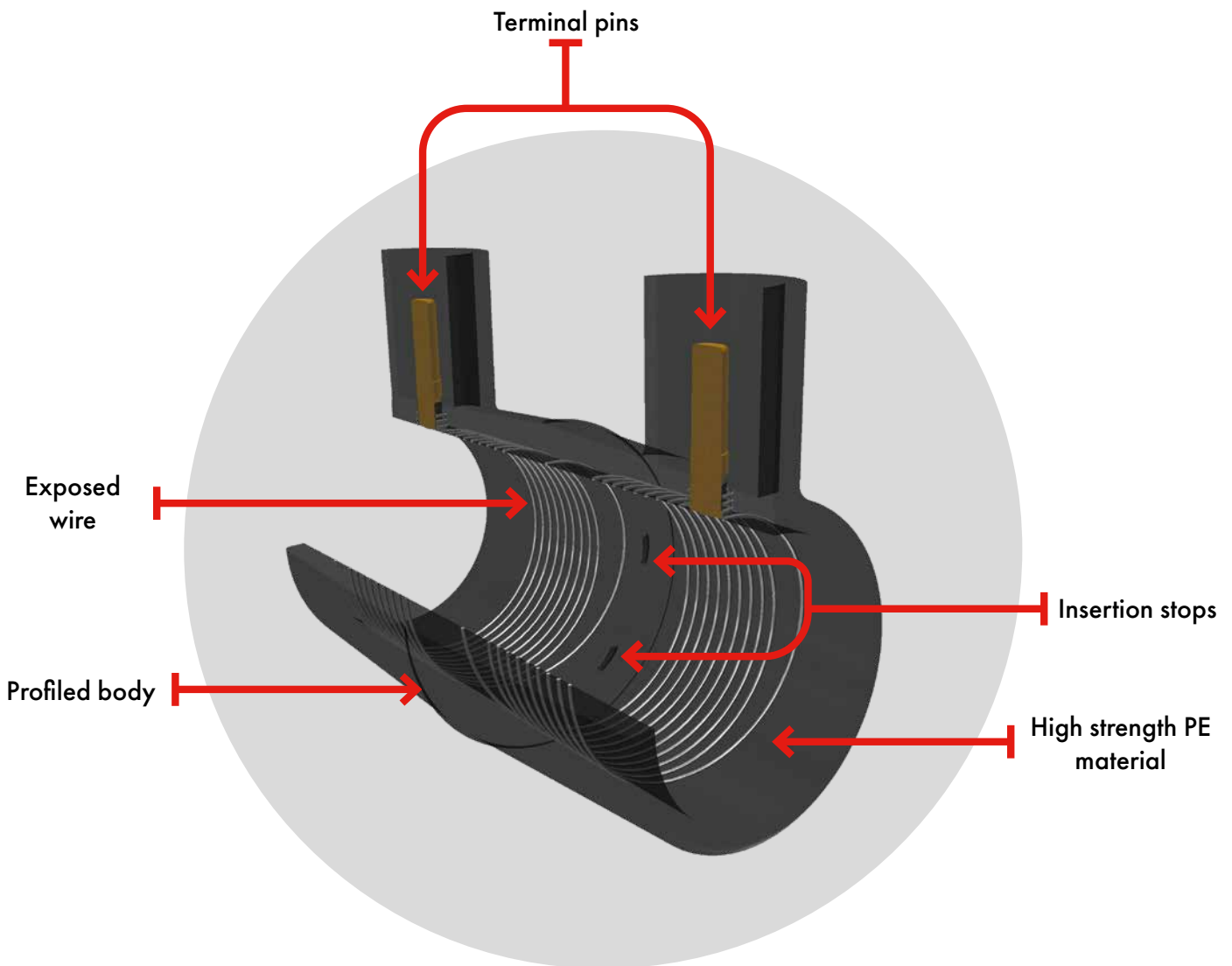

- Exposed wire technology for optimum heat transfer between the fitting and the pipe during the electrofusion process
- Available with 4.0 mm (40 Volt) and 5.7 mm (80 Volt) terminal pin connections to suit market requirements
- Manufactured from high strength PE100 for increased fitting integrity
- Profiled body for optimum material usage
- Fusion and traceability barcode technology



# **UNIVERSAL ELECTROFUSION FITTINGS FOR WATER, WASTEWATER, GAS, POWER & RENEWABLE ENERGY APPLICATIONS**

# Product Range

## Couplers

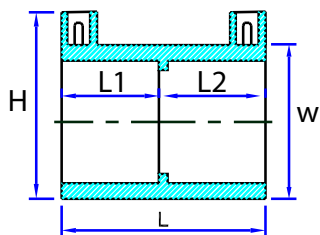

Nominal diameter mm	Pack qty	Dimensions mm					Max weight kg	Fuse time sec	Cool time min	Product code 40 V 4.0 mm pin
		H	L	L1	L2	W				
20	20*	52	83	40	40	29	0.03	40	4	WA0202
25	20	52	81	40	40	32	0.03	10	4	WA0203
32	20	61	81	40	40	42	0.05	18	4	WA0204
40	10	66	81	40	40	49	0.05	35	4	WA0205
50	10*	87	99	48	48	63	0.13	75	9	WA0206
55	10*	101	118	58	58	81	0.3	44	5	WA0207
63	10	98	105	52	52	77	0.16	28	5	WA0208
75	10*	113	125	62	62	93	0.31	120	14	WA0209
90	10	131	125	62	62	109	0.39	90	10	WA0210
110	4*	152	161	79	79	132	0.72	130	13	WA0211
125	4	168	157	77	77	151	0.88	120	15	WA0212
140	1	182	194	96	96	162	1.08	220	18	WA0213
160	1	209	186	92	92	195	1.81	300	22	WA0214
180	1	229	207	102	102	215	2.25	220	12	WA0215
200	1	260	211	106	102	246	3.49	400	16	WA0217
225	1	285	218	109	105	266	3.78	400	22	WA0221
250	1	315	220	109	105	296	4.26	480	30	WA0223
280	1	335	283	138	138	320	5.86	600	32	WA0227
315	1	387	266	133	129	380	8.6	850	33	WA0229
355	1	415	319	158	158	407	9.2	1150	65	WA0231
400	1	465	340	169	169	455	12.3	1750	60	WA0233

**Note:** \*Fittings available to purchase as individual items.

## SDR17 couplers



Nominal diameter mm	Pack qty	Dimensions mm					Max weight kg	Fuse time sec	Cool time min	Product code 40 V 4.0 mm pin
		H	L	L1	L2	W				
250	1	293	220	105	110	283	3.08	480	28	WA0224
315	1	362	266	133	129	356	5.68	660	36	WA0230

## Easigrip® couplers - 80 V

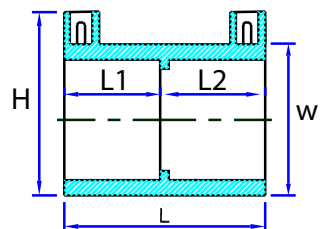
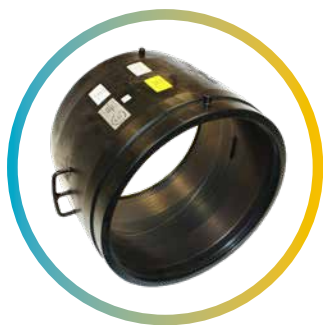

Nominal diameter mm	Pack qty	Dimensions mm					Max weight kg	Warm-up time sec	Soak time sec	Fuse time sec	Cool time min	Product code 80 V 5.7mm pin
		H	L	L1	L2	W						
355	1	415	319	158	158	407	9.2	-	-	700	35	WA0131
400	1	465	340	169	169	456	12.3	-	-	800	44	WA0133
450 <sup>1</sup>	1	526	376	187	187	517	17	180	600	700	45	WA0135
500 <sup>1</sup>	1	581	374	186	186	574	21.5	180	600	800	55	WA0137
560 <sup>1</sup>	1	647	398	197	197	647	27.4	500	900	2100	140	WA0139
630 <sup>1</sup>	1	720	407	202	202	720	33.6	600	900	2250	100	WA0140

**Note:**

1- Couplers use a 3-part 80 V electrofusion process. Compatible equipment must be used to weld the Easigrip® couplers. Please refer to the Easigrip® instruction details within this brochure.

Always refer to the fitting and packaging label for the most up to date information.

# Product News

## ENVIRONMENTAL BENEFITS OF 250mm AND 315mm SDR17 COUPLERS

### Significantly reduced fusion times

- Less energy needed to produce the weld - reducing fuel and emissions from a generator
- Quicker to install - more joints per day causing less environmental disruption

### Smart design

- Up to 33% reduction in PE materials
- Lightweight design



- Compatible with PE80 and PE100 pipes
- Exposed wire technology for optimum joint integrity
- Universal fitting for water and gas

# Product Range

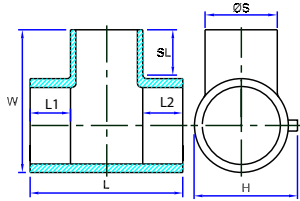

## Equal tees - spigot off-take

Nominal diameter mm	Pack qty	Dimensions mm							Max weight kg	Fuse time sec	Cool time min	Product code 40 V 4.0 mm pin
		H	L	L1	L2	ØS	SL	W				
20	20*	51	100	39	39	20	58	98	0.06	40	3	WA2202
25	20	54	100	37	37	25	58	98	0.07	48	4	WA2203
32	20	62	109	42	42	32	58	109	0.09	50	6	WA2204
40	10	71	128	46	46	40	65	119	0.15	70	7	WA2205
50	10*	86	143	50	50	50	70	140	0.24	70	6	WA2206
63	5	98	158	54	54	63	70	159	0.34	50	6	WA2208
75	1	115	200	59	59	75	118	220	0.67	120	14	WA2209
90	1	131	200	63	63	90	85	206	0.83	90	9	WA2210
110	1	155	251	80	80	110	135	282	1.85	180	13	WA2211
125	1	169	247	73	73	125	95	256	1.89	120	10	WA2212
140	1	185	305	91	91	140	145	325	3.1	260	16	WA2213
160	1	217	342	101	101	160	110	350	4.39	300	21	WA2214
180	1	240	362	106	106	180	130	371	6.21	280	19	WA2215

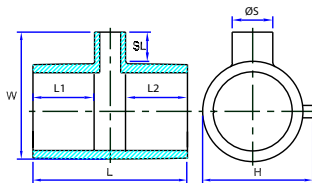

## Reducing tees - spigot off-take

Nominal diameter mm	Pack qty	Dimensions mm							Max weight kg	Fuse time sec	Cool time min	Product code 40 V 4.0 mm pin
		H	L	L1	L2	ØS	SL	W				
160x160x90	1	220	340	100	100	90	95	290	3.91	300	21	WA5350
180x180x90	1	230	361	105	105	90	110	345	4.9	280	19	WA5352

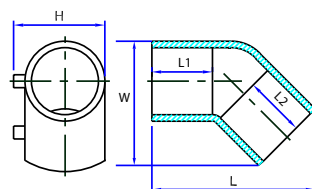

## 45° elbows

Nominal diameter mm	Pack qty	Dimensions mm					Max weight kg	Fuse time sec	Cool time min	Product code 40 V 4.0 mm pin
		H	L	L1	L2	W				
63	5	100	167	58	58	128	0.32	60	8	WA3316
75	5*	116	180	59	59	143	0.43	120	14	WA3317
90	5	132	222	77	77	176	0.82	80	9	WA3318
110	1	152	243	80	80	201	1.17	180	14	WA3319
125	1	175	269	82	82	228	1.84	90	7	WA3320
140	1	183	284	92	92	236	1.53	260	22	WA3321
160	1	216	326	100	100	280	3.31	300	21	WA3322
180	1	240	350	101	101	308	4.11	260	16	WA3323

**Note:** \* Fittings available to purchase as individual items.

Always refer to the fitting and packaging label for the most up to date information.

# Product Range

## 90° elbows

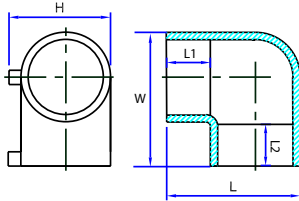

Nominal diameter mm	Pack qty	Dimensions mm					Max weight kg	Fuse time sec	Cool time min	Product code 40 V 4.0 mm pin
		H	L	L1	L2	W				
20	20*	50	74	41	41	74	0.04	44	4	WA3339
25	20	54	78	41	41	78	0.05	25	5	WA3340
32	20	63	85	40	40	85	0.08	55	7	WA3341
40	10	72	99	45	45	99	0.12	74	6	WA3342
50	10*	88	114	50	50	114	0.22	75	8	WA3343
63	5	100	143	58	58	143	0.4	60	8	WA3345
75	5*	115	158	59	59	158	0.54	120	13	WA3346
90	5	133	195	77	77	195	0.98	80	9	WA3347
110	1	154	218	80	80	218	1.39	180	14	WA3348
125	1	178	246	82	82	246	2.14	90	7	WA3349
140	1	185	266	92	92	266	1.85	260	20	WA3350
160	1	217	307	100	100	307	3.86	300	21	WA3351
180	1	240	329	101	101	329	5.16	260	16	WA3352

## Coupler cap

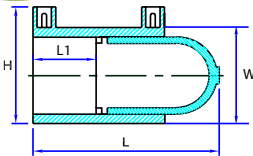

## End caps

Nominal diameter mm	Pack qty	Dimensions mm				Max weight kg	Fuse time sec	Cool time min	Product code 40 V 4.0 mm pin
		H	L	L1	W				
20 <sup>2</sup>	20*	52	92	40	29	0.04	40	4	WA1202
25 <sup>4</sup>	20	53	97	40	33	0.04	48	5	WA1203
32 <sup>2</sup>	20	61	106	32	42	0.07	18	4	WA1204
40 <sup>4</sup>	10	70	112	40	52	0.1	26	5	WA1205
50 <sup>4</sup>	10*	84	120	45	64	0.11	38	4	WA1206
55 <sup>4</sup>	10*	99	157	58	80	0.3	40	5	WA1207
63 <sup>3</sup>	10	101	96	61	77	0.15	30	5	WB1208
75 <sup>3</sup>	10*	114	106	68	91	0.23	40	4	WB1209
90 <sup>3</sup>	10	142	119	78	109	0.36	70	12	WB1210
110 <sup>4</sup>	4*	154	242	77	136	1.13	120	10	WA1211
125 <sup>3</sup>	4	180	137	86	151	0.72	100	11	WB1212
140 <sup>3</sup>	1	197	146	91	169	0.99	70	8	WB1213
160 <sup>2</sup>	1	209	310	92	195	3.13	300	22	WA1214
180 <sup>3</sup>	1	241	169	104	216	1.85	170	12	WB1215
200 <sup>4</sup>	1	262	350	113	246	4.63	360	27	WA1217
225 <sup>4</sup>	1	285	350	115	270	5.03	330	18	WA1221
250 <sup>4</sup>	1	312	365	109	296	6.57	440	22	WA1223

## 1-piece end cap

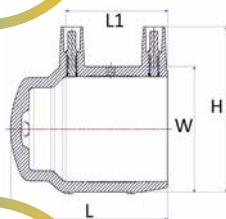

## Reducer cap

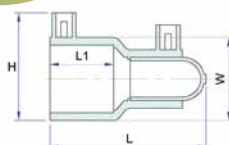

### Note:

- 2- Coupler cap
- 3- Electrofusion coupler and end cap
- 4- Electrofusion reducer and end cap

\* Fittings available to purchase as individual items.

Always refer to the fitting and packaging label for the most up to date information.

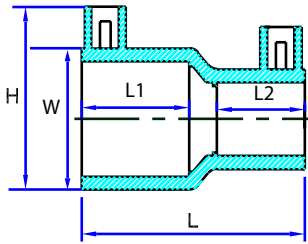

## Reducers

Nominal diameter mm	Pack qty	Dimensions mm					Max weight kg	Fuse time sec	Cool time min	Product code 40 V 4.0 mm pin
		H	L	L1	L2	W				
20 x 16	20*	49	81	40	40	29	0.04	12	2	WA4252
20 x ¾"	20*	56	80	39	40	38	0.05	36	3	WA4254
25 x 20	20	54	82	43	38	33	0.04	48	5	WA4258
25 x ¾"	20	56	80	39	40	38	0.05	30	4	WA4257
32 x 16	20	62	82	44	37	43	0.05	15	5	WA4259
32 x 20	20	62	89	44	39	43	0.05	36	6	WA4262
32 x 25	20	62	89	46	42	43	0.05	40	5	WA4263
32 x ¾"	20	62	83	42	40	44	0.05	14	3	WA4261
32 x 1"	20	64	83	42	40	45	0.06	60	5	WA4264
40 x 32	10	70	82	40	39	52	0.07	26	5	WA4269
50 x 32	10*	84	94	45	42	62	0.1	38	4	WA4270
63 x 32	10	98	117	51	42	77	0.16	55	10	WA4273
63 x 40	10	98	116	56	48	78	0.19	85	9	WA4274
63 x 50	10	99	117	56	47	78	0.2	90	9	WA4275
63 x 55	10	101	117	58	55	81	0.28	40	5	WA4277
63 x 2"	10	98	117	57	58	79	0.25	85	12	WA4276
75 x 63	10*	113	124	60	58	95	0.26	90	14	WA4280
90 x 63	10	133	154	80	60	117	0.5	120	10	WA4281
90 x 75	10	129	154	77	62	108	0.41	135	18	WA4282
90 x 3"	10	134	154	75	77	110	0.6	90	14	WA4283
110 x 63	4*	153	188	77	57	136	0.75	100	15	WA4284
110 x 90	4*	154	188	86	79	136	0.84	120	10	WA4286
125 x 63	4	177	164	91	63	159	0.96	160	18	WA4287
125 x 90	4	170	180	89	75	155	1.04	120	18	WA4289
125 x 110	4	177	169	85	76	158	1.38	140	12	WA4291
125 x 4"	4	176	164	80	80	156	1.35	140	13	WA4290
140 x 125	1	185	190	92	89	158	1.18	250	35	WA4293
160 x 110	1	218	231	96	85	197	1.84	180	18	WA4294
160 x 140	1	217	187	92	88	193	1.48	180	16	WA4348
180 x 125	1	231	200	93	79	216	1.9	280	24	WA4297
180 x 140	1	230	200	90	81	212	1.42	320	22	WA4299
180 x 160	1	236	206	102	97	216	2.1	200	14	WA4302
180 x 6"	1	238	202	99	99	220	2.82	360	31	WA4300
200 x 160	1	262	240	113	106	246	3.36	360	27	WA4303
225 x 160	1	285	240	115	106	270	3.81	330	18	WA4311
250 x 180	1	314	240	117	99	300	4.73	440	22	WA4319
280 x 250**	1	335	500	138	105	-	14.8	-	-	WA4352
315 x 250	1	390	275	133	110	380	8.26	520	21	WA4332

**Note:** \* Fittings available to purchase as individual items.

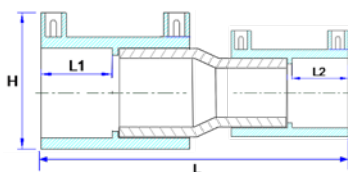

### \*\* Reducer kit:

- Consists of 1 x 280mm EF coupler, 1 x 250mm EF coupler, 1 x 280x250mm SDR17 spigot reducer
- Fittings components provided will be supplied loose, dimensions stated are for complete assembly.

Always refer to the fitting and packaging label for the most up to date information.

# Product Range



## Tapping tees - 32 mm outlet

Our range of tapping tees have been specifically designed with a universal integral cutter and NBR O-ring seal, approved for use in gas and water applications. Manufactured from high performance PE100 our tapping tees are designed with a Unifit™ base to suit a range of pipe diameters, considerably reducing the need to carry additional stock of fittings. Quick and easy to install, our tapping tees are available with a 32 or 63 mm outlet, in diameters 40 mm to 560 mm.

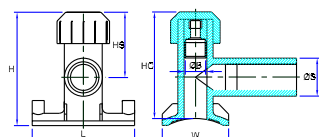

Nominal diameter mm	Pack qty	Dimensions mm							Max weight kg	Fuse time sec	Cool time min	Product code 40 V 4.0 mm pin
		ØB	H	HC	HS	L	ØS	W				
40 <sup>5</sup>	5	20	151	120	71	115	32	62	0.3	40	4	WA6333
55	5	20	136	110	71	115	32	67	0.3	55	4	WA6335
63 & 2"	5	20	141	110	71	115	32	77	0.3	55	4	WA6332
75	5	20	129	110	71	115	32	75	0.3	55	4	WA6337
90 & 3"	5	20	130	111	71	115	32	90	0.3	55	4	WA6331
110 - 140 & 4"	5	20	128	115	71	115	32	83	0.3	55	4	WA6330
140 - 180 & 6"	5	20	125	115	71	115	32	88	0.3	55	4	WA6342
200 - 250 & 8" <sup>6</sup>	5	20	122	115	71	115	32	90	0.3	55	4	WA6348
268 - 355 <sup>6</sup>	5	20	120	115	71	115	32	90	0.3	55	4	WA6359
400 - 560 <sup>6,7,8</sup>	5	20	118	115	71	115	32	90	0.3	60	4	WA6363



## Tapping tees - 63 mm outlet

Nominal diameter mm	Pack qty	Dimensions mm							Max weight kg	Fuse time sec	Cool time min	Product code 40 V 4.0 mm pin
		ØB	H	HC	HS	L	ØS	W				
63 & 2"	5	34	170	135	106	170	63	77	0.76	55	4	WA6460
75	5	34	166	143	106	170	63	100	0.76	55	4	WA6462
90 & 3"	5	34	166	135	106	170	63	100	0.76	60	4	WA6463
110 - 125 & 4"	5	34	162	137	106	170	63	105	0.76	70	4	WA6466
140 - 155	5	34	152	137	106	170	63	110	0.76	70	4	WA6467
155 - 180 & 6"	5	34	152	135	106	170	63	110	0.76	70	4	WA6471
200 <sup>6</sup>	5	34	146	135	106	170	63	110	0.76	70	4	WA6472
213 - 280 & 8" <sup>6</sup>	5	34	146	135	106	170	63	110	0.76	75	5	WA6476
315 - 355 <sup>6</sup>	5	34	144	135	106	170	63	110	0.76	80	4	WA6482
400 - 469 <sup>6,8</sup>	5	34	142	135	106	170	63	110	0.76	75	4	WA6486
500 - 560 <sup>6,8</sup>	5	34	139	135	106	170	63	110	0.76	80	5	WA6492

### Note:

- 5- Fitted with an under-part
  - 6- Fitted with a thread follower which must be removed after tapping the main. See guidance within this brochure
  - 7- Not suitable for use with 560mm SDR17 and SDR17.6 pipe
  - 8- Not suitable for use with SDR11 pipe
- ØB = cut hole diameter

For pipe connections identified in footnotes 7 and 8, please contact Radius Subterra our live pipeline engineering division on t: 01773 582317 or e: radius.subterra@radius-systems.com.

For the MOP of tapping tee products for gas applications, please refer to the packaging label

For instructions on how to install our tapping tees, please refer to the jointing guidance within this brochure.

Always refer to the fitting and packaging label for the most up to date information.

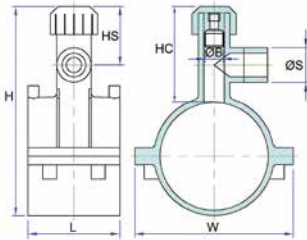

## Under-clamp tapping tees - 25 mm outlet

Our range of under-clamp tapping tees have been specifically designed with a universal integral cutter and NBR O-ring seal, approved for use in gas and water applications. Manufactured from high performance PE100 our tapping tees are designed for a dedicated range of pipe diameters. Quick and easy to install, our under-clamp tapping tees are available with a 25 or 32mm outlet, in diameters 40 mm to 160 mm.

Nominal diameter mm	Pack qty	Dimensions mm							Max weight kg	Fuse time sec	Cool time min	Product code - 40 V 4.0 mm pin
		ØB	H	HC	HS	L	ØS	W				
40	5	20	182	135	107	115	25	92	0.6	45	5	WB6292
50	5	20	192	135	107	115	25	99	0.6	55	5	WB6293
63	5	20	204	135	107	115	25	110	0.64	55	5	WB6295
75	5	20	216	135	107	115	25	124	0.67	55	5	WB6296
90	5	20	232	135	107	115	25	139	0.71	55	4	WB6297
110	5	20	252	135	107	115	25	159	0.78	55	4	WB6298
160	5	20	302	135	107	115	25	209	0.91	55	4	WB6303

## Under-clamp tapping tees - 32 mm outlet

Nominal diameter mm	Pack qty	Dimensions mm							Max weight kg	Fuse time sec	Cool time min	Product code - 40 V 4.0 mm pin
		ØB	H	HC	HS	L	ØS	W				
40	5	20	182	135	107	115	32	92	0.6	45	5	WB6333
50	5	20	192	135	107	115	32	99	0.62	55	5	WB6334
63	5	20	204	135	107	115	32	110	0.64	55	5	WB6336
75	5	20	216	135	107	115	32	124	0.66	55	5	WB6337
90	5	20	232	135	107	115	32	139	0.71	55	4	WB6338
110	5	20	252	135	107	115	32	159	0.75	55	4	WB6339
160	5	20	302	135	107	115	32	209	0.75	55	4	WB6344

### Note:

ØB = cut hole diameter

For the MOP of tapping tee products for gas applications, please refer to the packaging label

### Fuse and cool times

Fuse and cool times shown throughout the brochure are correct at the time of publishing. In line with Radius Systems' policy of continuous product development, fusion times may be subject to change. Always refer to the fitting and packaging label for the most up to date information.

# Product Range



## Branch saddles

Radius Systems offer a wide selection of specially designed branch saddles through our division Radius Subterra, who specialise in live pipeline engineering and offer a class leading service to carry out connections to all pipelines using our Minimus branch saddles.

Our branch saddles are manufactured in our state of the art production cell, with facilities to produce made to measure branch saddles that fit standard or bespoke pipe diameters. Please contact Radius Subterra for information on live connections, approvals and MOP:

e: [radius.subterra@radius-systems.com](mailto:radius.subterra@radius-systems.com)

t: +44 (0)1773 582317.

For third party installation, Radius Systems supply a range of branch saddles for gas, water and wastewater applications. Please contact us for more details.

Radius Subterra are certified by Lloyds Register under the Gas Industry Registration Scheme (GIRS), as well as the Achilles UDBV Verify for utility street works.

- Water & wastewater
- Gas

Pipe diameter	Flanged outlet size					Spigot outlet size		
	mm / inch	DN80	DN100	DN150	DN250	DN300	90 mm	125 mm
4"	-	-	• 4"xDN100	-	-	-	-	-
6"	-	-	• 6"xDN100	-	-	-	-	-
8"	-	-	-	• 8"xDN150	-	-	-	-
90mm	• • 90xDN80	-	-	-	-	-	-	-
110mm	• 110xDN80	• 110xDN100	-	-	-	-	-	-
125mm	• • 125xDN80	• • 125xDN100	-	-	-	-	-	-
140mm	• 140xDN80	• 140xDN100	-	-	-	-	-	-
160mm	• 160xDN80	• 160xDN100	-	-	-	-	-	-
180mm	• • 180xDN80	• • 180xDN100	• • 180xDN150	-	-	-	-	• 180x125
200mm	• 200xDN80	• 200xDN100	-	-	-	-	-	-
225mm	• 225xDN80	• 225xDN100	-	-	-	-	-	-
250mm	• • 250xDN80	• • 250xDN100	• • 250xDN150	• • 250xDN250	-	-	• • 250x90	-
268mm	• • 268xDN80	-	• • 268xDN150	-	-	-	• • 268x90	-
280mm	• • 280xDN80	-	• • 280xDN150	-	-	-	• • 280x90	-
315mm	• • 315xDN80	• • 315xDN100	• • 315xDN150	• • 315xDN250	-	-	• • 315x90	-
355mm	• • 355xDN80	• • 355xDN100	• • 355xDN150	• • 355xDN250	• • 355xDN300	-	• • 355x90	-
400mm	• • 400xDN80	• • 400xDN100	• • 400xDN150	• • 400xDN250	• • 400xDN300	-	• • 400x90	-
440mm	• 440xDN80	-	• 440xDN150	• 440xDN250	• 440xDN300	-	• • 440x90	-
450mm	• • 450xDN80	-	• • 450xDN150	• • 450xDN250	• • 450xDN300	-	• • 450x90	-
469mm	• 469xDN80	-	• 469xDN150	• 469xDN250	• 469xDN300	-	• • 469x90	-
500mm	• • 500xDN80	-	• • 500xDN150	• • 500xDN250	• • 500xDN300	-	• • 500x90	-
560mm	• • 560xDN80	-	• • 560xDN150	• • 560xDN250	• • 560xDN300	-	• • 560x90	-
630mm	• • 630xDN80	-	• • 630xDN150	• • 630xDN250	• • 630xDN300	-	• • 630x90	-
710mm	• 710xDN80	-	• 710xDN150	• 710xDN250	• 710xDN300	-	• 710x90	-
800mm	• 800xDN80	-	• • 800xDN150	• • 800xDN250	• • 800xDN300	-	• 800x90	-
900mm	• 900xDN80	-	• 900xDN150	• 900xDN250	• 900xDN300	-	• 900x90	-
1000mm	• 1000xDN80	-	• 1000xDN150	• 1000xDN250	• 1000xDN300	-	• 1000x90	-





# **INNOVATIONS BY RADIUS SYSTEMS FOR UP TO 2 BAR GAS APPLICATIONS**

# Product Range



## PurgeTee™

PurgeTee™ is Radius Systems' patented innovative solution to carry out all mains purging, pressure testing and bypass construction operations. Our PurgeTee™ brings additional benefits to gas operators and installers offering a more compact solution with reduced spigot length and height, delivering a reduced installation footprint.

Manufactured with a unique injection moulded elbow, fused in a factory controlled environment, our PurgeTee™ offers a fully welded solution which reduces the number of site made electrofusion joints for optimum system integrity. Quick and easy to install compared to alternative solutions, PurgeTee™ is designed with a Unifit® base to suit a range of pipe diameters and SDRs and is manufactured from high performance PE100.

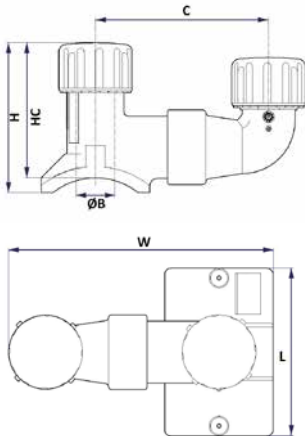

## PurgeTee™ - 32 mm outlet

Nominal diameter mm	Pack qty	Dimensions mm						Max weight kg	Fuse time sec	Cool time min	Product code 40 V 4.0 mm pin
		ØB	H	HC	C	L	W				
40 <sup>5</sup>	5	20	182	133	114	115	176	0.45	40	4	WA8333
55	5	20	148	116	114	115	174	0.45	55	4	WA8335
63 & 2"	5	20	153	122	114	115	179	0.45	55	4	WA8336
75	5	20	140	123	114	115	178	0.45	55	4	WA8337
90 & 3"	5	20	142	123	114	115	185	0.45	55	4	WA8338
110 - 140 & 4"	5	20	140	127	114	115	182	0.45	55	4	WA8341
140 - 180 & 6"	5	20	138	127	114	115	185	0.45	55	4	WA8342
200 - 250 & 8" <sup>6</sup>	5	20	134	127	114	115	185	0.52	55	4	WA8351
268 - 355 <sup>6</sup>	5	20	132	127	114	115	185	0.52	55	4	WA8359
400 - 560 <sup>6,7,8</sup>	5	20	130	127	114	115	185	0.52	60	4	WA8367

## PurgeTee™ - 63 mm outlet

Nominal diameter mm	Pack qty	Dimensions mm						Max weight kg	Fuse time sec	Cool time min	Product code 40 V 4.0 mm pin
		ØB	H	HC	C	L	W				
63 & 2"	3	34	171	135	176	170	252	1.27	55	4	WA8461
75	3	34	166	143	176	170	263	1.27	55	4	WA8462
90 & 3"	3	34	166	135	176	170	263	1.27	60	4	WA8463
110 - 125 & 4"	3	34	162	137	176	170	268	1.27	70	4	WA8466
140 - 155	3	34	152	137	176	170	268	1.27	70	4	WA8467
155 - 180 & 6"	3	34	152	135	176	170	268	1.27	70	4	WA8469
200 <sup>6</sup>	3	34	146	135	176	170	268	1.51	70	4	WA8472
213 - 280 & 8" <sup>6</sup>	3	34	146	135	176	170	268	1.51	75	5	WA8474
315 - 355 <sup>6</sup>	3	34	144	135	176	170	268	1.51	80	4	WA8482
400 - 469 <sup>6,8</sup>	3	34	142	135	176	170	268	1.51	75	4	WA8486
500 - 560 <sup>6,8</sup>	3	34	139	135	176	170	268	1.51	80	5	WA8492

### Note:

- 5 - Fitted with an under-part
- 6 - Fitted with a thread follower which must be removed after tapping the main.
- See guidance within this brochure
- 7 - Not suitable for use with 560 mm SDR17 and SDR17.6 pipe
- 8 - Not suitable for use with SDR11 pipe
- ØB = cut hole diameter

For pipe connections identified in footnotes 7 and 8, please contact Radius Subterra our live pipeline engineering division on t: 01773 582317 or e: radius.subterra@radius-systems.com.

For the MOP of tapping tee products for gas applications, please refer to the packaging label or contact Radius Systems.

For instructions on how to install our saddle fittings, please refer to the jointing guidance within this brochure.

# Product Range



## PurgeTee™ accessories & tooling (sold separately)

A reusable 1" (32mm) or 2" (63mm) adaptor is required to fit on the PurgeTee™ outlet, to facilitate pressure test or purge tooling connections.

The PurgeTee™ adaptor converts the PurgeTee™ moulded outlet thread to a BSP F thread, suitable for metallic purge stack connections.

Description	Product code
32 mm x 1" BSP-F adaptor	FT0655
63 mm x 2" BSP-F adaptor	FT0656
Short T key	FT0657





## Anaconda® - 25mm outlet

A smart and unique innovative flexible solution for gas service pipe connections, Anaconda® is Radius Systems' latest tapping tee innovation. Combining a PE100 tapping tee with a factory connected flexible 25mm PE80 service pipe outlet, Anaconda® minimises the number of electrofusion fittings and associated joints required to connect a service pipe to a gas main.

Approved to the UK gas specification GIS/PL2, Anaconda® is capable of accommodating horizontal and vertical changes between the main and the service pipe connection and offers a wide range of additional benefits over a traditional service pipe construction:

- Reduced number of fittings and joints in the system
- Reduced pipe preparation for electrofusion jointing
- Increased overall efficiency for service connection operations
- Significant installation time savings, leading to reduced network downtime

Trials show that the use of Anaconda® significantly reduces the time required to make a service pipe connection.

Nominal diameter mm	Pack qty	Dimensions mm										Max weight kg	Fuse time sec	Cool time min	Product code 40 V 4.0 mm pin
		ØB	H	HC	HS	L	L1	A1	A2	ØS	W				
40 <sup>5</sup>	1	20	151	120	71	115	546	366	46	25	62	0.43	40	4	GB8083
55	1	20	136	110	71	115	546	366	46	25	67	0.43	55	4	GB8085
63 & 2"	1	20	141	110	71	115	548	366	46	25	77	0.43	55	4	GB8086
75	1	20	129	110	71	115	547	366	46	25	75	0.43	55	4	GB8087
90 & 3"	1	20	130	111	71	115	555	366	46	25	90	0.43	55	4	GB8088
110 - 140 & 4"	1	20	128	115	71	115	552	366	46	25	83	0.43	55	4	GB8091
140 - 180 & 6"	1	20	125	115	71	115	554	366	46	25	88	0.43	55	4	GB8097
200 - 250 & 8" <sup>6</sup>	1	20	122	115	71	115	555	366	46	25	90	0.43	55	4	GB8103
268 - 355 <sup>6</sup>	1	20	120	115	71	115	555	366	46	25	90	0.43	55	4	GB8109

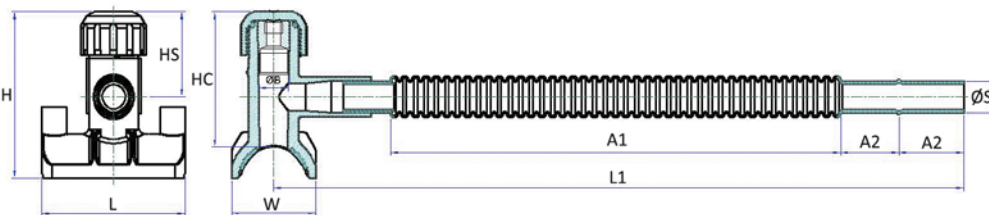

### Note:

5 - Fitted with an under-part

6 - Fitted with a thread follower which must be removed after tapping the main

ØB = cut hole diameter

For instructions on how to install our saddle fittings, please refer to the jointing guidance within this brochure.

### Fuse and cool times

Fuse and cool times shown throughout the brochure are correct at the time of publishing. In line with Radius Systems' policy of continuous product development, fusion times may be subject to change. Always refer to the fitting and packaging label for the most up to date information.



# ELECTROFUSION FITTINGS FOR UP TO 7 BAR GAS APPLICATIONS

Our range of electrofusion fittings for up to 7 bar applications are approved to the UK Gas Industry Specification GIS/PL2-4.  
An additional orange label is applied to the fittings to identify them as suitable for up to 7 bar pressure applications.

**Suitable  
for use up to  
7 bar**

# Product Range

## Couplers

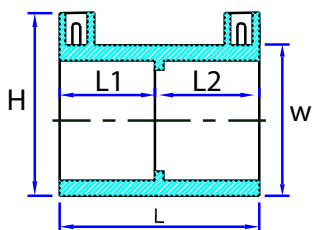

Nominal diameter mm	Pack qty	Dimensions mm					Max weight kg	Fuse time sec	Cool time min	Product code 40 V 4.0 mm pin
		H	L	L1	L2	W				
63	1	98	105	52	52	77	0.16	28	5	WB8258
90	1	131	125	62	62	109	0.39	90	10	WB8260
125	1	168	157	77	77	151	0.88	120	15	WB8262
180	1	229	207	102	102	215	2.25	220	12	WB8265
250	1	315	219	109	105	296	4.26	600	37	WB8273
315	1	387	266	133	129	380	8.6	850	33	WB8279

## Easigrip® couplers - 80 V

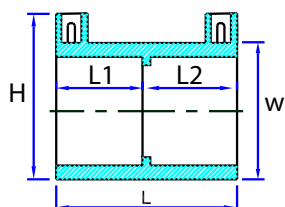

Nominal diameter mm	Pack qty	Dimensions mm					Max weight kg	Warm-up time sec	Soak time sec	Fuse time sec	Cool time min	Product code 80 V 4.0 mm pin
		H	L	L1	L2	W						
355	1	415	319	158	158	407	9.2	-	-	700	35	WA0331
400	1	465	340	169	169	456	12.3	-	-	800	44	WA0333
450 <sup>1</sup>	1	526	376	187	187	517	17	180	600	700	45	WA0335
500 <sup>1</sup>	1	581	374	186	186	574	21.5	180	600	800	55	WA0337

### Note:

- 1- Couplers use a 3-part 80 V electrofusion process. Compatible equipment must be used to weld the Easigrip® couplers. Please refer to the Easigrip® instruction details within this brochure.

## Equal tees - spigot off-take

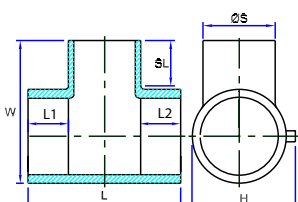

Nominal diameter mm	Pack qty	Dimensions mm							Max weight kg	Fuse time sec	Cool time min	Product code 40 V 4.0 mm pin
		H	L	L1	L2	ØS	SL	W				
63	1	98	158	54	54	63	70	159	0.34	50	6	WB2208
90	1	131	200	63	63	90	85	206	0.83	90	9	WB2210
125	1	169	247	73	73	125	95	256	1.89	120	10	WB2212
180	1	240	362	106	106	180	130	371	6.21	280	19	WB2215

Always refer to the fitting and packaging label for the most up to date information.

# Product Range

## 45° Elbows



Nominal diameter mm	Pack qty	Dimensions mm					Max weight kg	Fuse time sec	Cool time min	Product code 40 V 4.0 mm pin
		H	L	L1	L2	W				
63	1	100	167	58	58	128	0.32	60	8	WB3316
90	1	132	222	77	77	176	0.82	80	9	WB3318
125	1	175	269	82	82	228	1.84	90	7	WB3320
180	1	240	350	101	101	308	4.11	260	16	WB3323

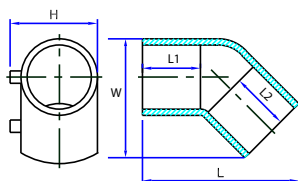

## 90° Elbows



Nominal diameter mm	Pack qty	Dimensions mm					Max weight kg	Fuse time sec	Cool time min	Product code 40 V 4.0 mm pin
		H	L	L1	L2	W				
63	1	100	143	58	58	143	0.4	60	8	WB3345
90	1	133	195	77	77	195	0.98	80	9	WB3347
125	1	178	246	82	82	246	2.14	90	7	WB3349
180	1	240	329	101	101	329	5.16	260	16	WB3352

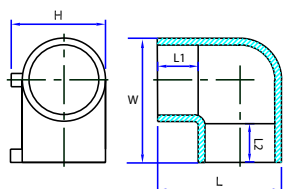

## Reducers



Nominal diameter mm	Pack qty	Dimensions mm					Max weight kg	Cool time sec	Fuse time min	Product code 40 V 4.0 mm pin
		H	L	L1	L2	W				
90 x 63	1	133	154	80	60	117	0.5	120	10	WB4281
125 x 63	1	177	164	91	63	159	0.96	160	18	WB4287
125 x 90	1	170	180	89	75	155	1.04	120	18	WB4289
180 x 125	1	231	200	93	79	216	1.9	280	24	WB4297
250 x 180	1	314	240	117	99	300	4.73	440	22	WB4319
315 x 250	1	390	275	133	110	380	8.26	520	21	WB4332

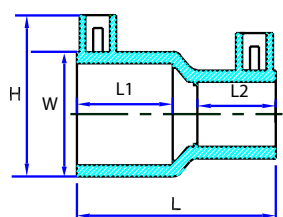

Always refer to the fitting and packaging label for the most up to date information.



1-piece end cap

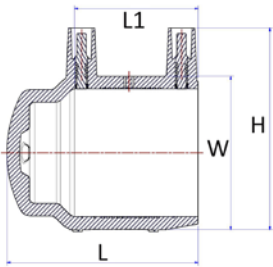

Reducer end cap

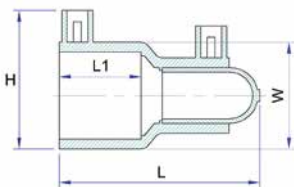

## End caps

Nominal diameter mm	Pack qty	Dimensions mm				Max weight kg	Fuse time sec	Cool time min	Product code 40 V 4.0 mm pin
		H	L	L1	W				
63 <sup>3</sup>	1	101	96	61	77	0.15	30	5	WB1808
90 <sup>3</sup>	1	142	119	78	109	0.36	70	12	WB1810
125 <sup>3</sup>	1	180	137	86	151	0.72	100	11	WB1812
180 <sup>3</sup>	1	241	169	104	216	1.85	170	12	WB1815
250 <sup>4</sup>	1	312	365	109	296	6.57	440	22	WB1323

### Note:

- 3 - 1-piece end cap
- 4 - Reducer cap

### Fuse and cool times

Fuse and cool times shown throughout the brochure are correct at the time of publishing. In line with Radius Systems' policy of continuous product development, fusion times may be subject to change. Always refer to the fitting and packaging label for the most up to date information.



# GUIDANCE INFORMATION



# Fitting label

## Confidence through traceability

All our fittings are supplied with traceability, and electrofusion welding parameter barcodes on one label applied to the body of the fitting. The traceability barcode identifies information such as the fitting type, the diameter, the manufacturer, the polyethylene compound, the material type, production batch etc.

In addition to the traceability label, we include permanent markings on our fittings, which meet with product specifications, maintaining quality control whilst reinforcing our fittings' traceability.

The barcode system gives installers using barcode enabled control boxes, the ability to scan and program the correct welding parameters, automatically taking into account the ambient temperature and at the same time, capturing the fitting's traceability information.

The electrofusion barcodes are formatted in accordance with:-

- ISO 13950 – Automatic recognition systems for electrofusion joints
- ISO 12176 Part 4 – Traceability coding

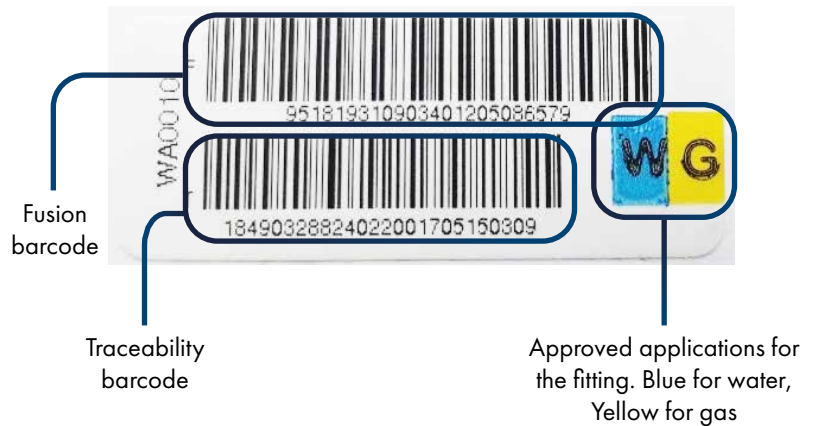

## What's on the packaging label?

- Electrofusion fitting type
- Maximum operating pressures in accordance with the relevant specification and application
- 6 character product code
- Fuse and cool times for manual input
- Application(s)
- Pipe SDR compatibility
- Manufacturing date
- Product batch number
- Fitting's weight
- Product approval(s)
- Manual fuse and cool time input for different temperature ranges
- Manufacturer's contact details

### WA0215

COUPLER 180 PE100 SDR11

180MM МУФТА ЧЕРНАЯ ПЭ100

Fuse Time (secs)	220	Время сварки, сек:
Cool Time (mins)	12	Время охлаждения, мин
SDR Range	11-26	Диапазон СПЗ
Application	GAS / WATER (W/P)	Применение
Fusion Voltage	40v	Напряжение сварки, Вольт
Manufacturing Date	2021/05	Дата производства (год, месяц)
Batch	N19	Номер партии
Weight (kg)	2.250000	Вес, кг
Quantity	1	Кол-во

GIS PL2-4  
4.7BAR

EN155  
10 BAR

EN12201  
16BAR

DV-8606BN0127

Manual Temperature Compensation /		данные для ручной корректировки			
Temperature °C	-30 to -19	-18 to -6	-5 to 23	24 to 37	38 to 50
Fusion Time, sec	260	243	220	202	186
Время сварки, сек	260	243	220	202	186

Radius Systems Ltd, Berrisford Lane, South Normanton, Airedale, Derby, DE66 2JJ, UK      +44(0)1773811112 www.radius-systems.com

Example of an electrofusion packaging label

# What's on a fitting?



## Handling electrofusion fittings

All our electrofusion fittings are supplied individually packaged, in a sealed bag to protect them from contamination.

- Installers should consider the weight and size of the fitting before lifting and handling
- Plan lifting tasks and consider the local site conditions when handling and transporting fittings
- Once the bag is removed, do not touch the internal surface of the fitting
- Protect the fitting from contaminants during installation, by replacing the bag on the open socket of the fitting

## How to store electrofusion fittings

Electrofusion fittings should be stored in their sealed packaging in a dry environment and away from direct sunlight and excessive heat.

They should be stored away from chemicals that may cause degradation or may be absorbed by the polyethylene material. If polyethylene products become contaminated, they should be disposed of safely, in accordance with local environmental regulations.

# Fusion circle



## Cleanliness

- Ensure the working area is free from contamination and protected from the elements.
- The electrofusion fitting must remain in its protective packaging until it is placed on the prepared pipe surface. Do not touch the prepared pipe and the fitting jointing surfaces.
- The clean pipe surface must be correctly prepared without excessive scraping. Industry approved pipe surface preparation tools must be used.
- If the prepared pipe surface becomes contaminated before making the electrofusion joint, it should be cleaned, dried and re-prepared using the approved tools and procedure, without excessive scraping.
- Once prepared, the joint must be assembled and made promptly to prevent contamination of the pipe surface.

## Pressure

- The pipe surface must be correctly prepared without excessive scraping, as this may lead to a poor quality fusion joint.
- When making a socket joint, the pipe ends must be cut square and must be fully inserted into the fitting's socket until it reaches the insertion stops.
- Where there is evidence of pipe ovality, the pipe must be re-rounded before the electrofusion fitting is placed on the pipe.
- Alignment clamps must be used for all electrofusion fittings.
- A calibrated tapping tee top loading clamp capable of applying the correct force must be used for top loading saddle fittings.

## Heat

- When making electrofusion joints, it is important to ensure that the generator (power supply) and the electrofusion control box are compatible with one another and must be capable of delivering the maximum power requirements at the stated voltage for the full duration of the fusion cycle.
- For Easigrip® couplers 450 mm and above, equipment compatible with Easigrip® couplers must be used. Please refer to the Easigrip® guidance within this brochure.
- The electrofusion alignment or top loading clamp must be left in place for the full duration of the fusion and cooling cycles.
- The fitting will remain hot to the touch beyond the prescribed cool time.
- If the electrofusion process is interrupted before the fusion cycle is completed, do not re-heat the fitting. The fitting must be replaced.
- The table below identifies the fitting's maximum power requirements at the stated voltage for the electrofusion process. These must be delivered to the fitting without interruption, for the full duration of the fusion time:

Fitting type	Terminal pin diameter	Fitting's maximum power requirement	Fitting voltage supply
Saddle fittings	4.0 mm	2.5 kW at 40 V rms	39 to 40 V rms
Socket fittings up to 280 mm	4.0 mm	2.5 kW at 40 V rms	39 to 40 V rms
Socket fittings 315 to 400 mm	4.0 mm	4.0 kW at 40 V rms	39 to 40 V rms
Socket fittings 315 to 400 mm	5.7 mm	4.0 kW at 80 V rms	78 to 80 V rms
Socket fittings above 400 mm	5.7 mm	4.8 kW at 80 V rms	78 to 80 V rms

# Electrofusion jointing guidance

The following general guidance provides an overview of the method used for making joints using the electrofusion jointing technique.

Installers of electrofusion fittings...

- Must be competent
- Have undertaken the appropriate industry training and assessment
- Have acquired the necessary knowledge
- Have experience of the jointing method

## Requirements to achieve a successful electrofusion joint

- The electrofusion process must be carried out as one continuous process from pipe surface preparation to fitting cooling stage
- Electrofusion jointing should be undertaken in a clean, dry and dust free environment. A shelter must be used to protect the work area from environmental contamination
- Where there is evidence of pipe ovality, the pipe must be re-rounded using industry approved equipment. Greater levels of ovality are found in coiled pipes, in pipes with higher SDRs and in diameters above 400mm
- The electrofusion equipment must be compatible, calibrated and capable of providing the correct fusion voltage for the full duration of the electrofusion cycle
- Alignment clamps must be used to ensure there is no movement between the pipe and fitting during the fusion and cooling processes
- For large diameter Easigrip® couplers, combined hydraulic re-rounding and alignment clamps must be used. For more guidance, please refer to the Easigrip® instructions detailed within this brochure
- For saddle fittings a top loading clamp is required. It should be calibrated and capable of applying the correct clamping force



## Quality assessment

- Following the electrofusion process, the fitting should be inspected to ensure that the fusion indicator(s) is (are) raised. The fusion indicator identifies that the electrofusion process has taken place. It is not confirmation of a quality joint
- For a good quality joint, there should be no visible melted material beyond the fitting's edges
- At the end of the electrofusion cycle, the control box should be checked to confirm that the cycle has completed without error
- The fusion joint record data should be retrievable for quality inspection or joint investigation
- Each joint should be marked with the joint reference details
- Follow industry approved pressure test procedures before commissioning the joint

# Electrofusion jointing guidance

## Easigrip® couplers jointing guidance and compatible equipment

Radius Systems' Easigrip® electrofusion couplers (450 to 630mm) must be installed using approved Easigrip® compatible equipment which is capable of delivering the 3 stage electrofusion heating cycle: 'warm-up', 'soak' and 'weld' (fuse), followed by the cooling cycle.

For successful jointing, a compatible electrofusion control box and matching generator capable of delivering a minimum constant power of 4.8 kW for the duration of the electrofusion cycle, are required (the fitting supply shall be 78 V to 80 V AC rms).

### Minimum equipment requirements

1. Easigrip® compatible 80 V electrofusion control unit
2. Generator capable of providing the required power for the full duration of the electrofusion cycle. A 7.5-10 kVA generator will be required depending on the manufacturer
3. Easigrip® compatible re-rounding clamps and alignment bars
4. Industry approved pipe surface preparation tool (rotary pipe preparation tool preferred. For ProFuse® pipe, use the pipe exposure tool - PET)
5. Welding shelter
6. Ground sheet
7. Measuring equipment
8. Approved marker pen
9. Suitable pipe cleaning equipment and disposable paper cleaning towels



**ONLY fusion equipment bearing the Easigrip® compatible label should be used with Easigrip® couplers.**

Compatible electrofusion control boxes can be obtained through a wide range of pipe jointing equipment suppliers. Please contact Radius Systems for more details.

### 3 stage electrofusion heating cycle

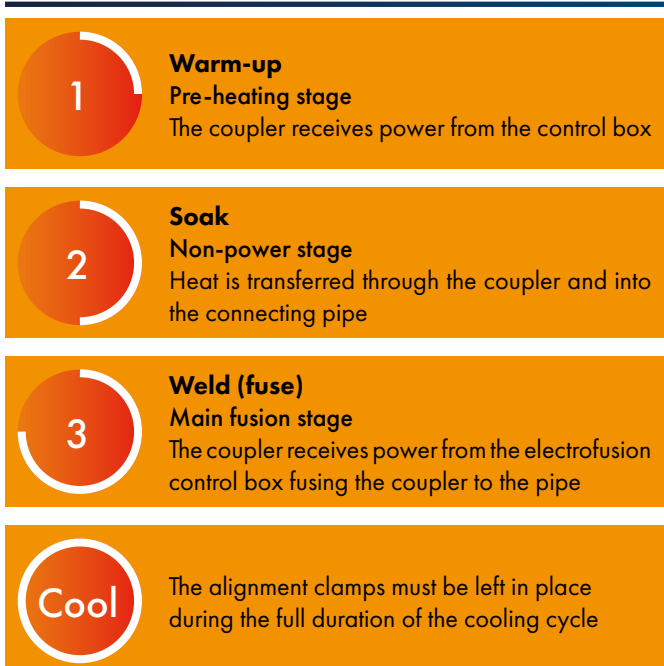

Minimum recommended personal protection equipment (PPE)



The weight of the electrofusion coupler is detailed on the packaging label. Please follow published safety practices when handling Easigrip couplers.



The fitting will remain hot to the touch beyond the prescribed cool time.



Before carrying out an electrofusion joint

- The inside and outside of the pipe must be completely dry
- Visually check all electrical components including the generator, electrofusion control box and all cables to ensure that they are in good working order and fit for use. Follow the supplier's recommendations
- Do not use the electrofusion fitting if the electrical terminal connections are damaged

## Socket fitting jointing overview using solid wall PE pipe for water and gas



1 Ensure the pipe to be joined is free from damage, cut square and re-rounded when required. The pipe's exterior and interior must be clean and dry.



2 Mark the fitting's insertion depth plus 25mm, using an approved marker pen. Mark the area to be prepared



3 Prepare the pipe surface using an industry approved rotary or hand scraping tool.

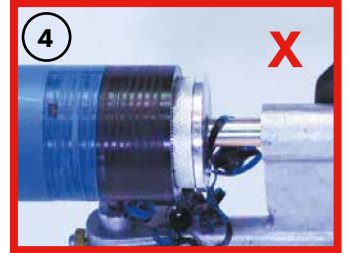

4 Do not remove excessive material during pipe preparation, as this may lead to a poor quality joint.



5 Inspect the scraped area and ensure it is correctly prepared, clean and free from contaminants.



6 Place the fitting on the pipe up to the insertion stops and mark the pipe as shown.



7 Follow steps 1 to 5 for the preparation of the connecting pipe surface and fully insert into the fitting's socket. Mark the pipe as shown in step 6.



8 Clamp the pipe joint in place and connect the electrofusion control box terminal leads to the fitting.



9 Follow the instructions on the electrofusion control box.



10 Scan or manually enter the fitting's fusion details into the control box and start the welding process.



11 Melt indicators show that the fusion process has taken place. It is not confirmation of a quality joint. Clamps must remain in place during the full cooling period.



12 Remove the clamps after the cooling period has elapsed. The joint is complete. Follow industry approved pressure test procedures before commissioning the joint.



Keep the environment clean,  
by removing all pipe shavings and offcuts  
and dispose of them responsibly.

# Electrofusion jointing guidance

## Socket fitting jointing overview using ProFuse® peelable pipe for water and gas

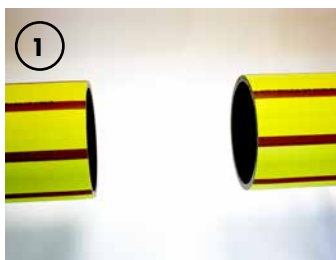

1  
Ensure the pipe to be joined is free from damage, cut square and re-rounded when required. The pipe's interior must be clean and dry.

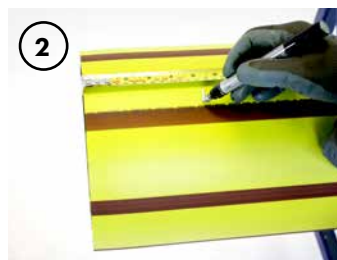

2  
Using an approved marker pen, mark the fitting insertion depth plus 25mm, on the pipe.

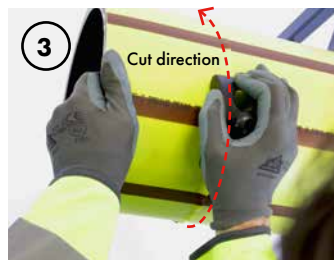

3  
Using the ProFuse® pipe exposure tool (PET), score the outer skin around the circumference of the pipe. **DO NOT USE** open bladed knives

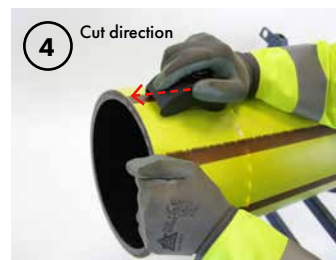

4  
Rotate the ProFuse® PET 90° and score the outer skin axially, starting on the circumferential cut to the edge of the pipe.



5  
Lift and pull the edge of the outer skin away from the core pipe and peel the skin. Take care not to contaminate the pipe surface.



6  
Place the fitting on the pipe up to the insertion stops and mark the pipe. Leave the fitting in its packaging.



7  
Repeat stages 2 to 5 for the preparation of the connecting pipe and fully insert into the fitting's socket.



8  
Mark the pipe and follow steps 8 to 12 on the previous page to weld and commission the fitting.

**Note:** If the exposed pipe surface becomes contaminated during the skin removal process, the core pipe should be treated as a solid wall pipe and prepared using a rotary pipe surface preparation tool

ProFuse® PET - Product code: FT0648

- The only tool recommended for the quick, simple and safe removal of the ProFuse® skin
- The PET tool must be used, **DO NOT USE** open bladed knives
- The minimum recommended skin removal is the fitting's socket depth plus 25mm
- For butt-fusion jointing, remove a minimum 25mm wide strip, to ensure enough of the core polyethylene material is exposed for the jointing process



## Top loading tapping tee jointing guidance using solid wall PE pipe for water and gas

Radius Systems' tapping tee products, including PurgeTee™ and Anaconda® are supplied with an integral cutter within the body of the tapping tee. This is a 'non-captive cutter'. During the commissioning of the tapping tee product, some let-by of gas or water past the cutter threads may occur. This is normal and consistent with the design functionality of the tapping tee and will cease once the commissioning operation is complete. It is essential that the following tapping tee installation guidance is adhered to.

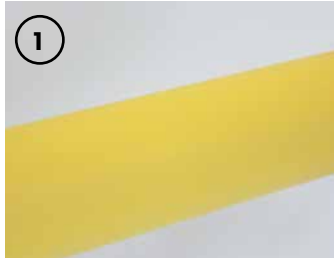

1 Inspect the pipe and ensure it is free from damage and the pipe surface is clean and dry.



2 Using the saddle fitting as a guide, mark the outline area of the pipe to prepare for electrofusion jointing, using an approved marker pen.



3 Mark the area as shown using a cross hatch pattern to indicate the area to be prepared.



4 Prepare the pipe surface using an industry approved hand scraping tool.

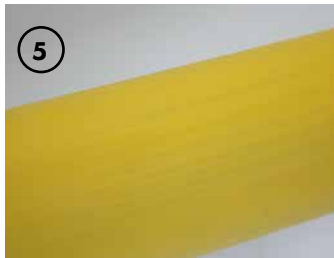

5 Inspect the pipe surface and ensure it is clean and free from contamination.



6 Using an approved calibrated clamp, secure the saddle fitting in place. Ensure the correct clamping force is applied (check clamp indicator).



7 Connect the electrofusion control box terminal leads to the fitting and follow the instructions on the control box.



8 Melt indicators show that the fusion process has taken place. It is not confirmation of a quality joint. Clamps must remain in place during the full cooling period.



9 Prepare the outlet of the tapping tee and place the socket fitting onto the outlet. Prepare the service pipe and make the socket joint following the socket fitting jointing procedure within this brochure.



10 Tapping the main  
Use a 12 mm hexagonal T key and turn in a clockwise direction until the cutter cuts through the top of the main

Retracting the cutter  
Turn the T key in an anti-clockwise direction until the top of the cutter is flush with the top of the stack.



11 Do not remove the cutter from the stack. Ensure the top of the cutter is flush with the top of the stack.

**Removal of the cutter will result in an uncontrolled release of fluid from the pipeline.**



12 Check the O-ring seal is in place at the top of the stack and adequately tighten the cap. Check for leakage using industry best practice. The connection and commissioning are now complete.

Pressure test the service before commissioning.

### IMPORTANT NOTE

A thread follower is supplied with our range of large diameter tapping tees in sizes 200mm and above. Where a thread follower is included, a white label will be visible when the tapping tee cap is removed.

Thread followers ensure that the threads within the body of the tapping tee products are not overstressed when tapping the main. The follower should be retracted and removed when the tapping operation is complete. Do not remove the cutter from the stack. Ensure the top of the cutter is flush with the top of the stack.

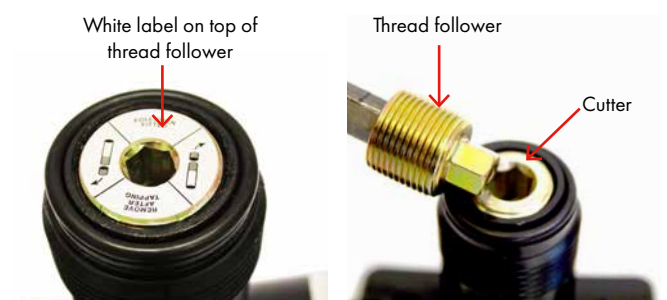

# Electrofusion jointing guidance

## Top loading tapping tees jointing guidance using ProFuse® peelable pipe for water and gas



Using the tapping tee as a guide, mark the outline area of the pipe to prepare for electrofusion jointing, using an approved marker pen.

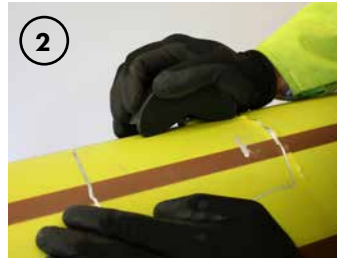

Using the ProFuse® PET, score and cut the outer skin around the perimeter of the marked area. **DO NOT USE** open bladed knives.

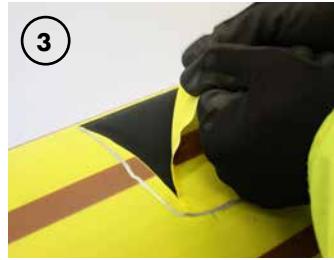

Lift and pull the edge of the outer skin away from the core pipe and peel the skin. Take care not to contaminate the pipe surface.

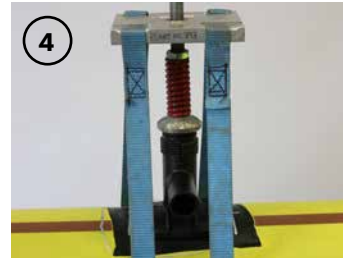

Once the outer skin is removed, follow steps from the 'Top loading tapping tee jointing guidance' section within this brochure to complete the connection.

**Note:** If the exposed pipe surface becomes contaminated during the skin removal process, the core pipe should be treated as a solid wall pipe and prepared using an approved pipe surface preparation tool

## 40 x 32 mm under-clamp saddle fitting jointing guidance



The 40 x 32 mm under-clamp tapping tee is supplied with a separate underpart.



Prepare the pipe surface following the 'Top loading tapping tee jointing guidance' within this brochure. Place the fitting on the pipe. Position and slide the underpart in the groove of the upper saddle as shown.



Hold the upper saddle firmly while tapping the underpart with a suitable soft-blow hammer to fully engage the underpart.



Follow steps from the 'Top loading tapping tee jointing guidance' section within this brochure to complete the connection.

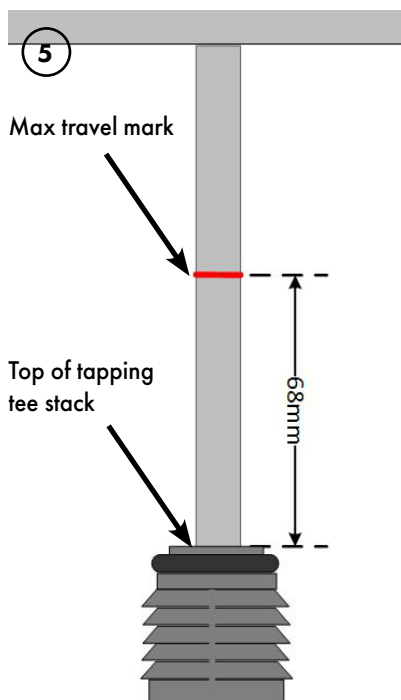

### Tapping the main

- Remove the cap
- Ensure the top of the cutter is at the top of the tapping tee stack
- Insert the 12 mm hexagonal T key into the cutter
- Mark the T key to indicate the maximum length of travel required = 68 mm
- Turn the T key clockwise until the maximum travel mark is flush with the top of the stack. The top of the pipe has now been cut through
- Retract the cutter by turning the T key anti-clockwise until the top of the cutter is flush with the top of the stack
- Do not remove the cutter from the stack
- Remove the T key, replace the cap and fully tighten
- Check for leakage using industry best practice. The connection is complete

Cutter position at the top of stack before and after pipe cut through



## PurgeTee™ for gas applications - Principle of operation

1

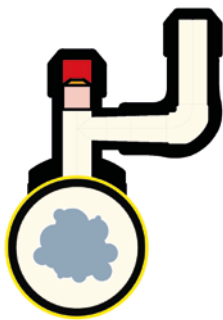

Fuse the PurgeTee™ onto the PE main, using the same procedure for saddle fittings in this document.

Remove the outlet cap and carry out a pressure test to prove weld integrity.

2

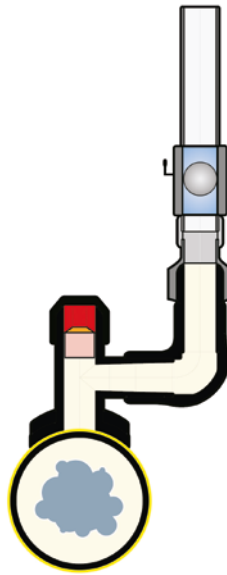

Fit the purge tube to the PurgeTee's elbow outlet using the reusable thread adaptor (product code FT0655 or FT0656).

3

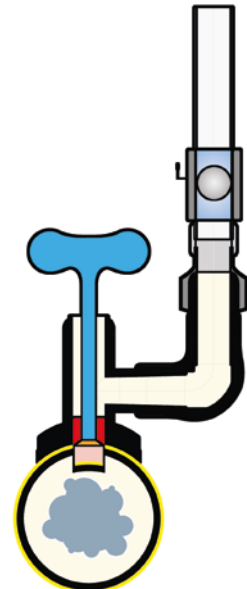

Using a short arm T key, tap the PE main. Retract the cutter to the top of the stack. Do not remove the cutter. (Follow tapping the main instructions for saddle fittings within this brochure)

4

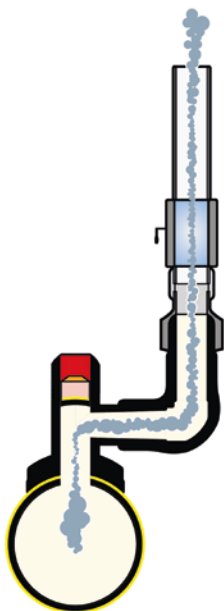

Open the valve on the purge tube to allow the gas / air to escape through the PurgeTee™.

5

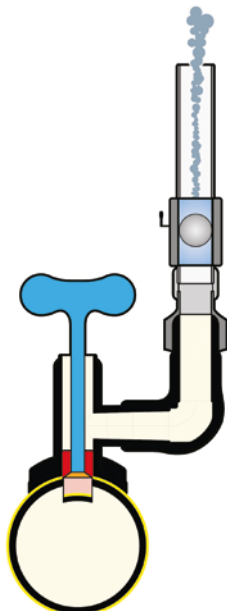

When the purging operation is complete, close the valve and wind the cutter down, so that it plugs the cut hole in the crown of the PE pipe.

6



Now that the flow of gas is controlled, remove the purge tube and adaptor. Check the O-ring seal is in place at the top of the stack and adequately tighten the cap. Check for leakage using industry best practice procedures.

For complete jointing guidance and jointing videos, please visit our website [www.radius-systems.com](http://www.radius-systems.com).  
For further jointing advice, please contact our technical support team on: t: +44 (0)1773 811112,  
e: [techsupport@radius-systems.com](mailto:techsupport@radius-systems.com).

## **Why do Radius Systems electrofusion fittings use exposed wire technology?**

Exposed wire technology means that the metallic heating element is visible, whilst being embedded within the fitting's body. Radius Systems consider that the exposed wire technology provides a more efficient heat transfer during the electrofusion process, whilst increasing joint integrity.

---

## **I want to use an electrofusion coupler as a repair coupler. Is this possible and what do I need to do?**

Electrofusion couplers may be used as repair couplers by removing the fitting's centre stops; these can be cut off at the base to create a clear bore. It is important that the fitting's internal surface, including the heating element, do not become damaged or contaminated during the removal of the stops.

---

## **Why are there 2 different terminal pin dimensions for electrofusion fittings?**

Different terminal pin diameters are used for 40 and 80 Volt fittings:

- 4.0 mm terminal pins are used for 40 Volt electrofusion fittings
- 5.7 mm terminal pins are used for 80 Volt electrofusion fittings in larger diameter.

The larger diameter fittings with a 5.7mm terminal pin need a higher voltage input to make the weld using the correct control box and leads.

## **I have stock of identical fitting's, but with different electrofusion fuse and cool times. Why is this?**

Radius Systems have a programme of continuous product development and improvement and this may result in changes to a fitting's design, including changes to a fitting's fuse and cool times. The correct fuse and cool times for each fitting are identified on the individual fitting's packaging label. Always refer to the packaging label for the fitting's details but if in doubt, please contact Radius Systems.

---

## **Radius Systems have supplied fittings with 4.0 mm terminal pins. However, my electrofusion control box is fitted with 4.7 mm terminal pin connection leads. How should I proceed?**

Terminal pin adaptors are available to convert the terminal pin connection leads from 4.7 mm to 4.0 mm. These pin converters are available from electrofusion tooling and equipment suppliers.

---

## **When making connections onto coiled pipes, I have noticed that the pipe is not truly circular, unlike straight pipes. What should I do to carry out an electrofusion joint?**

When polyethylene pipes are supplied in coil format, there will be a greater level of pipe ovality than that of pipe supplied in straight lengths. The pipe should be re-rounded using approved re-rounding clamps where the joint is going to be made.

## **Why do I need to prepare the pipe surface before making an electrofusion joint?**

To ensure a successful welded connection is achieved, it is important that when a joint is made, no contaminants are present at the joint interface or within the welded connection. During storage, transportation, handling and installation, the external surface of a polyethylene pipe will become contaminated with dirt and debris, which must be removed before making an electrofusion joint, using recommended pipe surface preparation techniques (see jointing overview within this brochure).

---

## **When preparing the surface of a solid wall polyethylene pipe for electrofusion jointing, what equipment should I use?**

For tapping tee connections, an industry approved 'hand scraper' should be used. For socket fittings, industry approved rotary pipe surface preparation tools are preferred. Such tools have the added benefit of removing a continuous layer of polyethylene material around the pipe's circumference for the full length of the socket.

---

## **Once I have prepared the pipe surface for electrofusion jointing, how long can I leave the pipe surface exposed before I make the joint?**

Making an electrofusion joint is a continuous process and once the pipe surface has been prepared, the electrofusion joint should be made without delay. Delay in making the joint, may result in contamination of the pipe surface, which could lead to premature failure of the electrofusion joint.

---

### **Can I prepare the pipe surface and then use wipes to remove airborne dust and dirt?**

The use of wipes to remove airborne dust and dirt is not recommended as the final method for pipe preparation. The only acceptable method of final pipe surface preparation is the use of a hand or rotary pipe scraper. Wipes and towels are only recommended to remove dust and dirt before using a hand or rotary scraper.

---

### **Why is it recommended to use a welding shelter when making electrofusion joints?**

Welding shelters are recommended to ensure that environmental contamination on the surfaces to be joined is minimised:

- Airborne dust in dry weather
- Rain and moisture in wet conditions

When making an electrofusion joint, dust, dirt, rain and moisture act as contaminants and will reduce the quality of the electrofusion joint, if present between the pipe and fitting's jointing surfaces.

---

### **Why do I need to leave the fitting in its packaging right up to the point of connection?**

Electrofusion fittings are supplied in sealed packaging to prevent contamination of the jointing surfaces. It is therefore recommended that the packaging is only removed at the point of connection to eliminate contamination of the fitting's jointing surface.

### **Why do I need to use electrofusion alignment clamps?**

Electrofusion alignment clamps are used for pipe to socket fitting connection and ensure that the pipe and fitting are in true alignment with one another and that there is a uniform gap between the pipe's outer surface and the fitting's internal surface. This ensures that during the heating phase of the electrofusion process the molten material is evenly distributed around the annular gap between the pipe and the fitting to ensure joint quality.

---

### **Why do I need to use a top loading clamp when making a tapping tee connection onto a pipeline?**

Top loading clamps are used with top loading tapping tees to ensure that the correct force is applied between the tapping tee body and the connecting pipe and achieve the correct weld interface pressure during the electrofusion process. Failure to adequately clamp the tapping tee body will result in incorrect fusion pressure and potential premature failure of the electrofusion joint.

---

### **When making an electrofusion fitting joint, what is the power requirements and what size of generator do I need?**

The size of generator is fully dependent on the age and efficiency of the generator. Please refer to the power requirements and generator size table within this brochure. The generator supplier will be able to confirm the generator size required for a given fitting.

### **If my generator runs out of fuel part way through the electrofusion process, is it acceptable to add more fuel to the generator and continue from where I left off?**

It is important to check the generator and ensure that there is an adequate amount of fuel to complete the electrofusion process, before making a joint. If a generator runs out of fuel part way through the fusion cycle, the electrofusion process should be terminated and under no circumstances should a second electrofusion process be undertaken. Once cool, the fitting must be removed from the system.

---

### **Once I have satisfactorily welded a tapping tee onto a pipeline, is it acceptable to proceed to tap into the live main?**

Tapping into the main should only take place after the tapping tee's cooling time has elapsed and the fitting is fully cooled. All joints should be tested for leak tightness before tapping the live main.

---

### **What equipment do I need to tap into the main?**

Radius Systems' tapping tees are fitted with an integral cutter. A 12mm T Key is recommended to commission the tapping tee as it allows the application of a symmetrical torque to the tapping tee when cutting through the main. Radius Systems do not recommend the use of single arm, ratchet or power tools when commissioning tapping tees due to the potential damage to the tapping tee internal threads.

**Sales:**  
t: +44 (0) 1773 811112  
e: Sales@radius-systems.com

**Technical support:**  
t: +44 (0) 1773 811112  
e: Techsupport@radius-systems.com

## In which position should the tapping tee cutter be, once I have commissioned the service?

The tapping tee cutter must always remain in the tapping tee. The top of the cutter should be flush with the top of the tapping tee stack.

Cutter position at top of stack after tapping the main



## Why is there a thread follower included with the large diameter tapping tees?

The thread follower included in all large diameter tapping tees 200 mm and above, is designed to ensure that the threads within the body of the tapping tee are not overstressed when tapping the main.

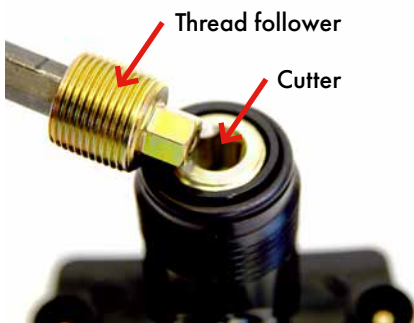

## How do I know if there is a thread follower in the tapping tee?

A thread follower is included in all tapping tees 200 mm and above. It is positioned directly above and engaged in the tapping tee cutter. A white label is applied to the top of the thread follower to indicate its presence.



Thread follower label on tapping tees 200 mm and above

## Once I have commissioned the tapping tee, should I leave the thread follower in the fitting?

The thread follower is used solely for the tapping tee commissioning procedure and should be removed once the procedure is completed. Retract the thread follower to the top of the tapping tee stack and remove carefully. The cutter must remain in the tapping tee. Ensure that the top of the cutter is flush with the top of the tapping tee stack.

## Is it normal for the fitting's external surface to become hot during and immediately after the electrofusion heating cycle?

Electrofusion joints are made by applying a constant voltage to the fitting's terminal connections, which causes the fitting's heating element to become hot. This in turn, heats the adjoining pipe surface, resulting in a homogeneous melt between the pipe and fitting. This heating process causes the fitting to become hot during and for some time after the heating cycle. Do not touch the fitting until it has fully cooled.

## The fitting's external surface remains hot beyond the prescribed cool time. Is this normal?

Yes. The cooling time is designed to allow the molten PE material to solidify. Once the cooling time has elapsed, the clamps can be removed. However, the fitting's external surface will remain hot and should not be touched until it has fully cooled.

## Why do Radius Systems' large diameter electrofusion fitting's use a 3 stage heating cycle?

Radius Systems' large diameter electrofusion couplers use a 3 stage heating cycle - heat - soak - weld, to ensure that the heat between the fitting and the pipe is uniformly transferred for optimum joint quality. The 3 stage heating cycle also allows for the fusion of the fitting to be carried out as one operation and specific electrofusion control boxes capable of delivering this 3 stage heating cycle are required. Please refer to the Easigrip® section within this brochure for more details.

**Why are Radius Systems' electrofusion fittings supplied with both manual (fixed) fusion time and barcode (variable) fusion time and what is the difference between them?**

The manual (fixed) fusion time, which is embossed on the fitting, is intended primarily for the UK market and is suitable for electrofusion jointing at an ambient temperature range between  $-5^{\circ}\text{C}$  and  $+23^{\circ}\text{C}$ .

The barcode fusion time, which is variable, with built-in ambient temperature compensation, is suitable for jointing at temperatures between  $-30^{\circ}\text{C}$  and  $+50^{\circ}\text{C}$ . The electrofusion fitting heating duration is automatically adjusted at the point of making the joint. An electrofusion control unit with barcode scanning capability is required to read the electrofusion barcode.



## Radius Systems

Radius Systems are a market leader in the innovation and manufacture of plastic pipe systems for the utilities and construction industries. With extensive research and development at the heart of our products and systems, we take care of the entire pipe life cycle - from design and manufacture through to installation, repair and rehabilitation. We strive to improve industry practices, with good health and safety policies at the forefront of our philosophy of 'getting it right first time'. Our continuous customer inspired research and development, combined with successful customer partnerships represent our total dedication to the plastic piping industry.

- **Manufacturing facilities**

With 2 production sites in the UK, we have complete control over quality and the ability to meet our customers' expectations.

- **Innovative approach**

We are leaders in our field with a history of research and new product development. Practicality, durability and adaptability are all high on our agenda to meet our clients' needs.

- **Flexible product and service provision**

Our comprehensive range of services is designed to fit the variable demands of our clients' developments in pipes, fittings, training and support services.

- **Reliability and safety**

With over 50 years experience in pipe design and manufacture, our clients know that they can count on us to meet not just their product and service needs, but also their delivery and safety requirements.

- **Dedicated customer service team**

We have a knowledgeable team to answer queries from our customers in the UK and overseas. Our service is not just about the delivery of products - contact our team if you have a product or installation enquiry or a post-delivery query.

For more information please visit our website  
[www.radius-systems.com](http://www.radius-systems.com)

### Technical support:

t: +44 (0) 1773 811112

e: [techsupport@radius-systems.com](mailto:techsupport@radius-systems.com)



### UK Head Office

Radius Systems Ltd  
Radius House, Berristow Lane  
South Normanton, Alfreton  
Derbyshire  
DE55 2JJ, UK

t: +44 (0) 1773 811112

e: [sales@radius-systems.com](mailto:sales@radius-systems.com)

### Northern Ireland and Republic of Ireland sales

Radius Systems  
Halfpenny Valley Industrial Estate  
Parkview Street, Portadown Road  
Lurgan, Co Armagh  
BT66 8TP, UK

t: +44 (0)28 4066 9999

e: [info@radius-systems.com](mailto:info@radius-systems.com)

### Find us on

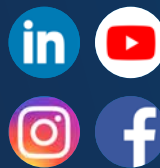

**RADIUS**  
SYSTEMS

[www.radius-systems.com](http://www.radius-systems.com)

#### DISCLAIMER

Radius Systems have made every effort to ensure that the information contained within this document is accurate. No legal responsibility will be accepted for any errors or omissions, whether they result from negligence or other cause. Radius Systems will not accept any legal responsibility or claim for consequential loss or otherwise, resulting from the use of this information. It is provided in good faith and remains entirely the responsibility of the recipient(s) to satisfy themselves at all times of the applicability of this information in relation to a given application or project.

As part of the Radius Systems program of continuous improvement, we reserve the right to amend the content of this publication without notice. The information supplied in this document is correct at the time of publication.